

LINE: HAND WRAPPING MACHINE

MODEL: TS-500



| USE | SPECIFICATIONS | |
|--|-----------------------|------------------|
| Ideal for wrapping meat, cheese and other items | Model | TS 500 |
| | Construction | Stainless steel |
| | Width | 52 cm / 20.5" IN |
| | Depth | 65 cm / 25.6" IN |
| | Height | 11 cm / 4.3" IN |
| | Weight (With no roll) | 6.4 kg / 14 lb |
| | Fuse | 2 Amp |
| | Volts | 115 / 60 |

BENEFITS

- * Hygiene and excellent presentation for your products
- * Easy to use
- * Practical and portable, designed to sit on a table
- * Roll adjustment
- * Heated teflon plate

LINE: HAND WRAPPING MACHINE

MODEL: TS-500

BENEFITS



SAVINGS

Optimize film with its film adjusting control



HYGIENE AND EXCELLENT PRODUCT PRESENTATION

Your products will have an excellent and hygienic presentation for its comercialization.



The hand wrapping machine TS-500 model allows a hygienic product presentation and keeps products dust-free.

SPECIFICATIONS

| | |
|-----------------------|--------------------------------|
| Model | TS 500 |
| Construction | Stainless steel |
| Film Roll* | Up to 18" width (Not included) |
| Weight (without roll) | 6.4 Kg / 14 lb |
| Fuse | 2 Amp |
| Voltage | 115/60 |

* Holds different film roll sizes, 45 cm/ 17.8", 38cm/15", 35cm/14" & 30 cm/12" width



PRACTICAL AND PORTABLE

Practical light-weight design to sit on a table and its indicator lights (power on, cutter and heated plate) alert the user about the elements in operation avoiding accidents.



TEMPERATURE CONTROL OF HEATED TEFLON PLATE

It allows to adjust the plate temperature for a better sealed packaging

EQUIPMENT DIAGRAM

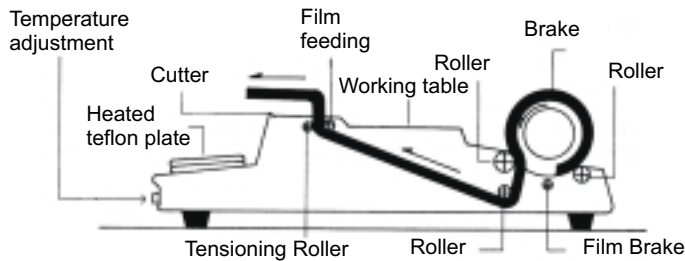

DIMENSIONS

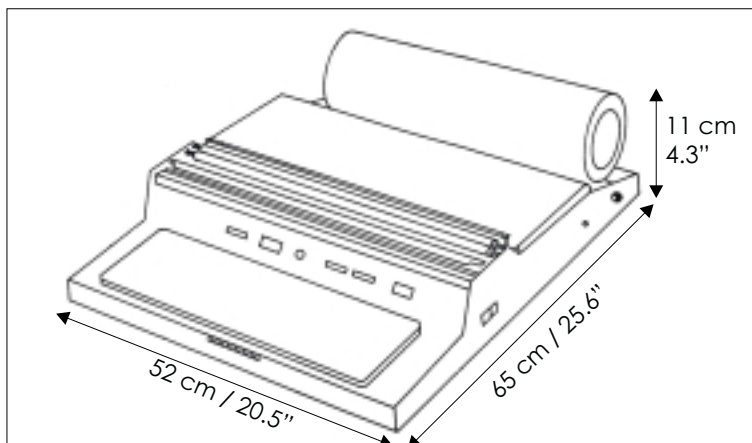

Holds film rolls 30cm/12", 35 cm/14", 38 cm/15" or up to 45cm/ 17.8" width, 50 & 55 caliber.



Note: Rolls Sold separately

DISTRIBUTED BY

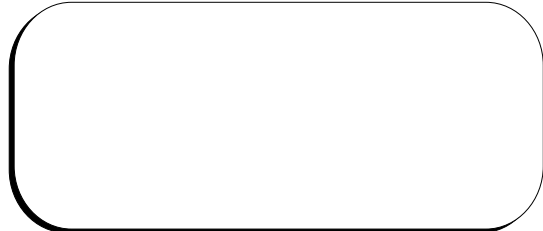

ALL INFORMATION IS SUBJECT TO CHANGE WITHOUT NOTICE